

# HD4V

## VACUUM/PRESSURE PUMP (CCW OR CW)

**165 CFM**



*Over 115 Years of Excellence*

Masport Rotary Vane Pumps are designed and engineered to give you the reliable pumping performance you need for the task at hand. With long hours and waste to be removed, you need a pump you can rely on. With over 100 years of experience in the vacuum/pressure pump industry, you can be confident in choosing Masport pumps and systems for your vacuum pump needs.

*Built to work as hard as you do.*

### CUSTOMER SERVICE WHEN YOU NEED IT

Our customers are our top priority. Any questions you have about your vacuum pump set-up, we're help you along the way.

### QUALITY & PERFORMANCE

- ▶ Designed for Tank Sizes up to 1,500 gallons
- ▶ 165 CFM
- ▶ 1 ½" NPT Connections
- ▶ Air Cooled
- ▶ Available in CW/CCW Rotations
- ▶ Achieve Minimum 27" HG (Intermittent)
- ▶ 1-Year Performance Warranty

### DESIGNED FOR DURABILITY & EASY OPERATION

- ▶ Heat Stabilized Kevlar Vanes
- ▶ Heavy-Duty Bearings and Viton Oil Seals
  - For longer pump life
- ▶ Durable, High-Temperature, Translucent Oil Lines
- ▶ End Thrust Protection
  - Prevents rotor-to-end cover contact and wear

### INTEGRATED COMPONENTS

- Pump Identifier Tag with QR Code
  - Quickly scan for replacement parts, manuals, and more
- Oil Pump Cover
  - To protect the life of oil pump
- Automatic Beka Oil Pump



# HD4V // VACUUM / PRESSURE PUMP

## Performance Data – Vacuum

PUMP R.P.M	DISPLACEMENT C.F.M	S.C.F.M and A.C.F.M @ VACUUM											MAXIMUM VACUUM – “Hg	
		5	10	15	18	20	22	24	25	26	27	CONTINUOUS	INTERMITTENT	
1100	122	SCFM	103	78	57	41	33	23	15	12	7.2	3.7	20	27
		ACFM	121	117	114	103	99	86	75	72	53	37		
1225	137	SCFM	116	88	63	46	37	26	16	14	9.6	4.1	20	27
		ACFM	136	132	127	115	111	97	80	78	71	41		
1400	165	SCFM	132	100	72	53	42	30	19	16	11	4.7	20	27
		ACFM	155	150	145	132	126	112	95	84	81	47		

## Performance Data – Pressure

PUMP R.P.M	DISPLACEMENT C.F.M	S.C.F.M @ P.S.I.G								MAXIMUM PRESSURE – P.S.I.G	
		5	10	15	18	20	25	30	CONTINUOUS	INTERMITTENT	
1100	122	102	97	93	87	82	77	72	20	30	
1225	137	115	109	104	98	92	87	81	20	30	
1400	165	131	125	119	112	105	99	92	20	30	

## Horsepower Required @ “Hg

PUMP R.P.M	VACUUM “Hg				
	5	10	15	20	27
1100	4.4	4.7	4.9	5.4	5.9
1225	4.9	5.2	5.5	6.0	6.6
1400	5.6	5.9	6.3	6.9	7.5

## Horsepower Required @ P.S.I.G

PUMP R.P.M	P.S.I.G				
	5	10	15	20	27
1100	4.9	6.9	8.7	10.7	12.4
1225	5.5	7.7	9.7	11.9	13.8
1400	6.3	8.8	11.0	13.6	15.8

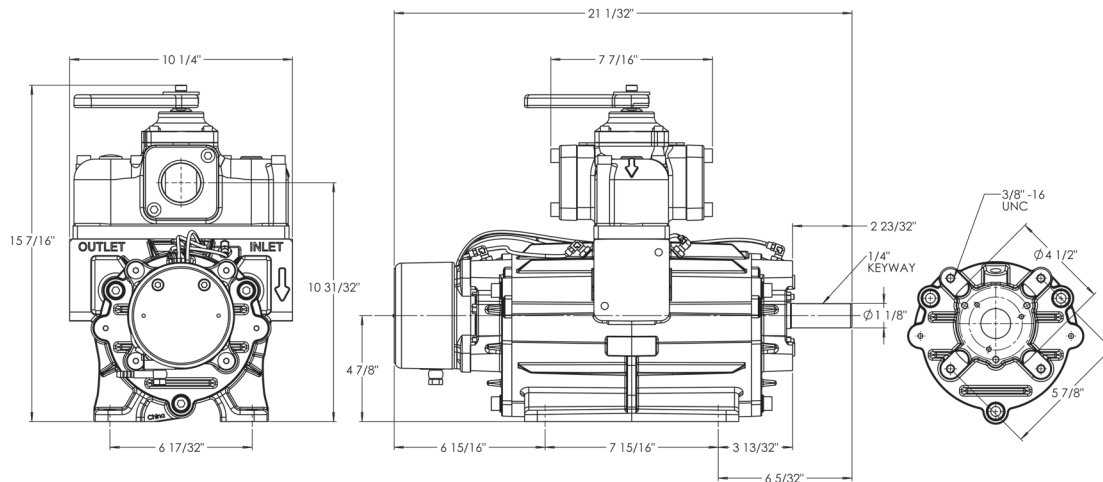

Explore more pumping supplies online at [MASPORTPUMP.COM](http://MASPORTPUMP.COM)

**Pump Replacement Parts**  
Rebuild, Gasket & Seal, and Vane Kits

**Pump Fluids**  
Vacuum Pump Oil and Flushing Fluid

**Vacuum Tank Components**  
Sight Glasses, Oil Separators, Scrubbers, and more.

**Gearboxes, Couplers, and Bases**  
Superior Brand Gearboxes, Rexnord & Woods Couplers, and more.